

Torusmachine build with Rotocast technique

Conny Högmark

IEA

LTH

conny.hogmark@iea.lth.se

Abstract

A prototype of a Torusmachine was build to see if it was possible to make a high torque torusmachine with rotocast technique.

In the fall of 2006 a project started to see if it was possible to make a torusmachine with a new rotocast technique. The torusmachine has been quite difficult to produce to a economic cost in the past, even though the machine has advanced to an ordinary electrical machine. With this new cast technique the production cost has potential to be reduced and an economic torusmachine could be produced. This is why it is very interesting to make a prototype and see if it is possible to use the cast technique to make a torusmachine with a high torque. Usually when an electrical engine is produced the engine is built up with sheets of metal to minimise the iron losses in the machine and after this the copper wire are placed. To produce an electrical machine today is a very multistep procedure. If the production steps can decrease this will probably decrease the production cost as well.

Torusemachine

The principle for this torusemachine is a fix stator and the rotor is on the outside of the machine. NeFeB magnets are fixt on the rotor and surrounds the stator on three sides.

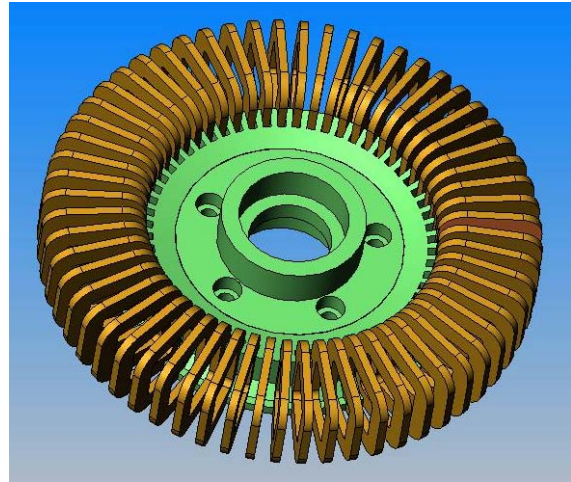
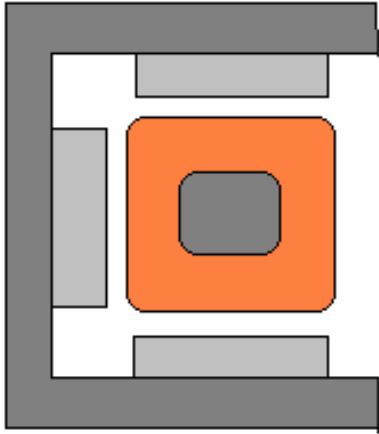

Picture 1 and 2. A view of the stator with surrounding magnets and how the stator is constructed with coils.

The stator is constructed with 60 coils, the coils builds up the torus in the stator. These coils are divided by three to get a 3 phase machine with 20 coils in each phase.

The rotor is on the outside off the machine and can therefore give a high torque to the axis in the centre off the machine. The rotors inside are covered with NeFeB magnets in 20 poles on three sides of the machine to give the high torque. The rotor is constructed in two parts the front and the back peace.

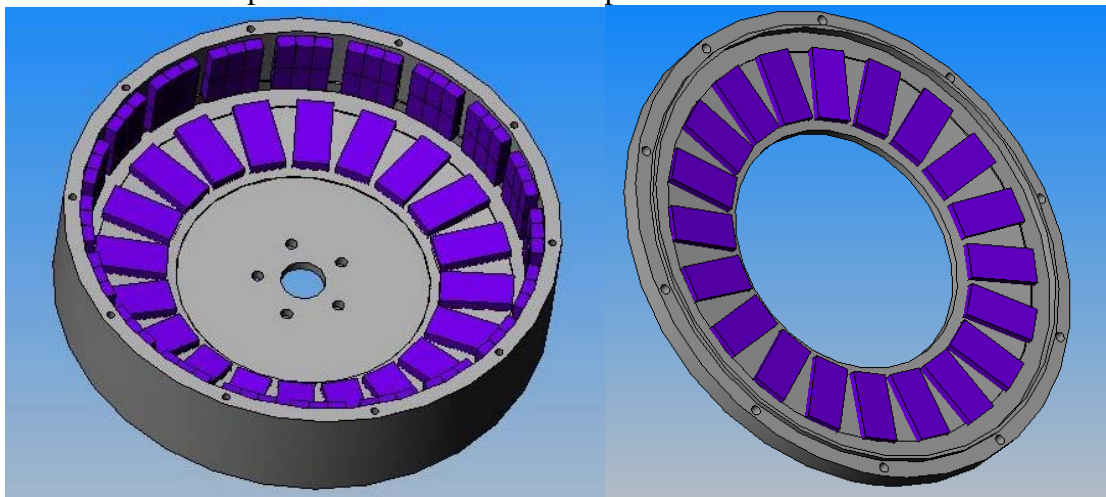

Picture 3. The front peice to the left and the back peice to the right.

Casting

The theory behind rotocast is to compress iron powder with rotation, to make the compressed iron powder stabile in its compressed form an plastic component is added to bind the iron powder together to a stabile mass and the result is to make a highly formable magnetic conductor that has less iron losses than ordinary magnetic conductors. The stator vas made in this way and the results was this.

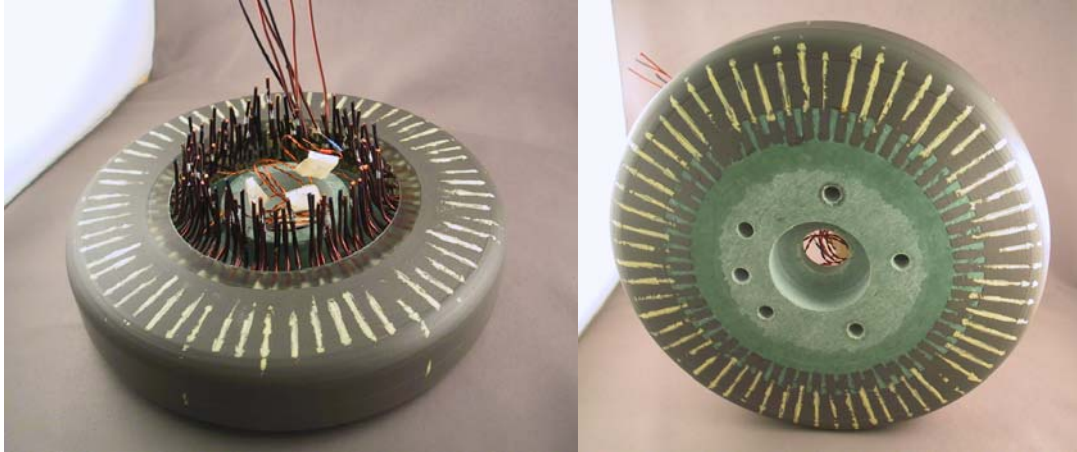

Picture 4 and 5. The rotocasted stator where the coils are visible.

Assemble

To assemble the motor there is some perks the biggest one of them all is the strength of the magnets. But with help of a turnmachine and some threaded steel pole the assembly went painless.



Picture 6. The torusmachine assembled and working.

Test results

The test is made with 3 of 7 magnets/pole and therefore only can give a rough idea of the performance of the machine. But we can see if it seems promising and if there are some indicators that we are on the right track. So what are the expectations of the torusmachine?

- Torque 25 Nm when I_{sy} is 20 A this give a phase current of 11.5 A.
- A higher efficiency with a higher rpm due to fewer losses in the iron core.

Torque

To be able to measure the torque of the Torusmachine a direct current machine was needed to break the Torusmachine. From the direct current machine the torque was calculated and the results were.

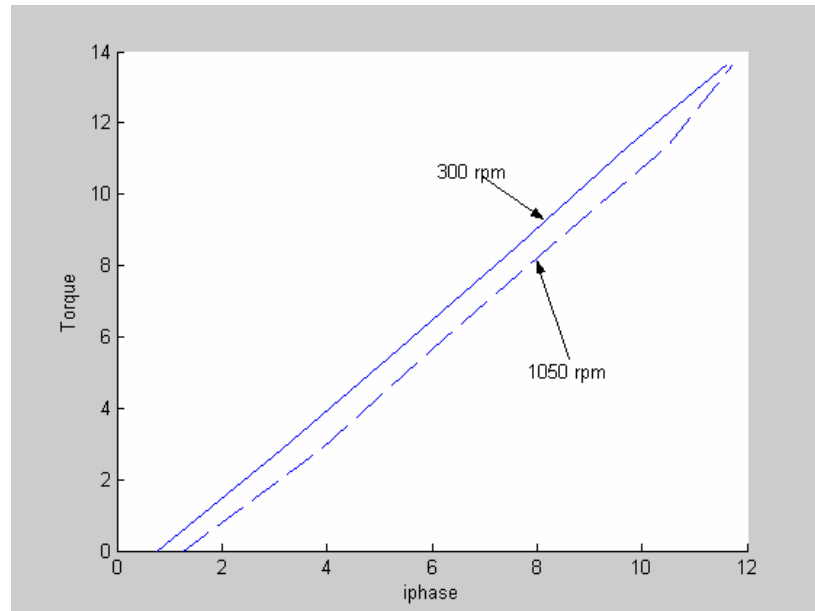

Picture 7. Torque measurements at a variable phase current.

Efficiency

The efficiency was calculated with two different measurements at a different range of frequency and results was

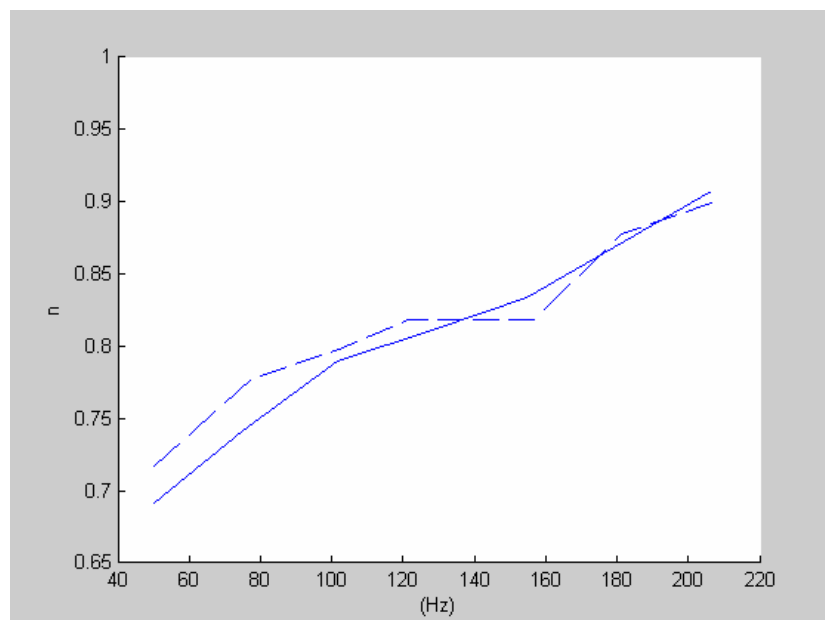

Picture 8. Efficiency at variable frequency.

Results

To sum up the first rough measurements and see if the results that was expected did occur.

1. Is it possible to make a stator with rotocast technique? Yes it is. The combination of plastic and iron powder does work.
2. Did the Torusmachine give the expected torque? The torusmachine gave 13.5 Nm when the phase current was 11.5 A and the torusmachine was only magnetised with 3/7 magnets so with 7/7 magnets the torque will roughly be doubled that means 27 Nm when the phase current is 11.5 A and that is what was expected.
3. The efficiency did grow with the rpm as expected.

Well is everything all good now? Not exactly, there is still some perks that have to be tested more

- The torusmachine has a high cogging torque and this can have some negative tendencies.
- There is some heat development in the torusmachine and since the heat has difficulties to get out of the machine it just accumulates.

So there are still some things to test and figure out to next generation torusmachine and also the machine shall be tested with all of the magnets in place but for now life is good.